

Sharkoon

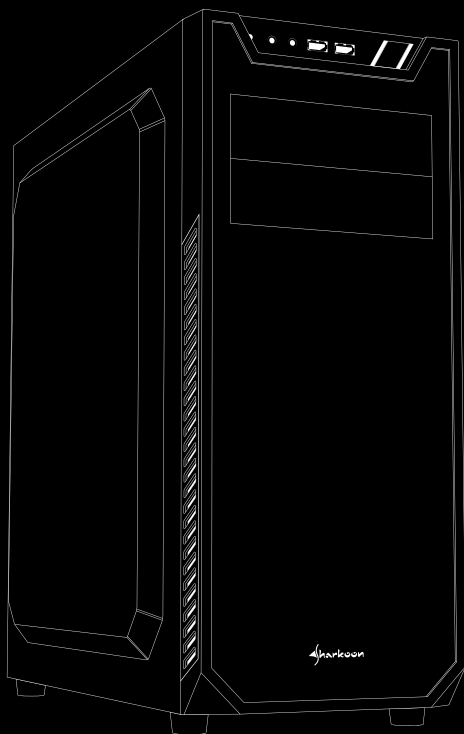

V57

Manual • Anleitung • Manuel • Manuale dell'utente • Handleiding  
Instrukcja • Használati útmutató • Manuál • 使用説明 • マニュアル

# Specifications

- Spezifikationen
- Spécifications
- Specifiche tecniche
- Especificaciones
- Especificações
- Specificaties

- Specyfikacja
- Műszaki adatok
- Specifikace
- Technické údaje
- 規格
- 仕様

## General:

## VS7

## VS7 Window

■ Form Factor	ATX	ATX
■ Expansion Slots	7	7
■ Interior Painting	✓	✓
■ Tool-Free Devices Installation	✓	✓
■ Cable Management System	✓	✓
■ Side Panel	Metal	Acrylic
■ Color Versions	Black	Black
■ Dimensions (L x W x H)	45.0 x 22.1 x 47.3 cm	45.0 x 22.1 x 47.3 cm

## I/O:

■ USB 3.0 (Front)	2	2
■ Audio (Front)	✓	✓

## Drive Bays:

■ 5.25"	1	1
■ 5.25" or 3.5" External	1	1
■ 5.25" to 3.5" Bay Cover	1	1
■ 3.5" or 2.5"	2	2
■ 2.5"	2	2

## Fan Configuration:

■ Front Panel	1x 120 mm Fan (Pre-Installed) or Radiator (Optional)	2x 120 mm Fan (Pre-Installed) or Radiator (Optional)
■ Rear Panel	1x 120 mm Fan (Pre-Installed)	1x 120 mm LED Fan (Pre-Installed)
■ Side Panel	2x 120 mm Fan (Optional)	
■ Top Panel		3x 120 mm or 2x 140 mm Fan (Optional)

## Compatibility:

■ Mainboard	Mini-ITX, Micro-ATX, ATX	Mini-ITX, Micro-ATX, ATX
■ Max. Length Graphics Cards	40.0 cm	40.0 cm
■ Max. Height CPU Cooler	16.5 cm	16.5 cm
■ Max. Length Power Supply	24.0 cm	24.0 cm
■ Max. Height Radiator incl. Fan (Front)	5.9 cm	5.9 cm
■ Max. Height Radiator incl. Fan (Top)		5.0 cm

## Package Contents:

- VS7/VS7 Window, Accessory Set

## 5.25" Device Installation

- Einbau 5,25"-Laufwerk
- Installation du périphérique 5,25"
- Installazione unità da 5,25"
- Instalación de dispositivo 5,25"
- 5,25" Instalação de dispositivo
- Installatie 5,25" apparaat
- 5,25" монтаж urządzeń
- 5,25" eszköz beszerelhetőség
- Instalace 5,25" jednotky
- Inštalácia 5,25" zariadenia
- 5.25" 装置安裝
- 5.25 インチデバイスの取付け

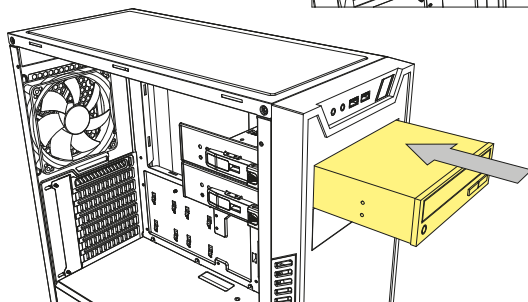
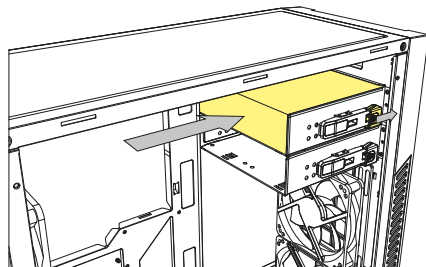
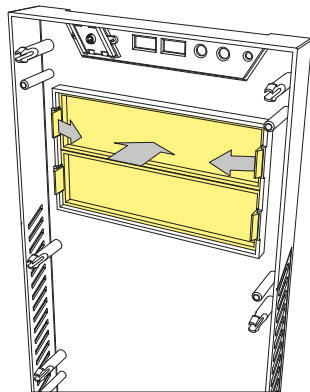

## 3.5" External Device Installation

- Einbau 3,5"-Laufwerk (Extern)
- Installation du périphérique externe 3,5"
- Installazione unità esterna da 3,5"
- Instalación externa de dispositivo 3,5"
- 3,5" Instalação de dispositivo externo
- Installatie 3,5" apparaat (extern)
- 3,5" zewnętrzny montaż urządzeń
- 3,5" külső eszköz beszerelhetőség
- Instalace externí 3,5" jednotky
- Inštalácia externého 3,5" zariadenia
- 3.5" 外接装置安裝
- 3.5 インチ外付けデバイスの取付け

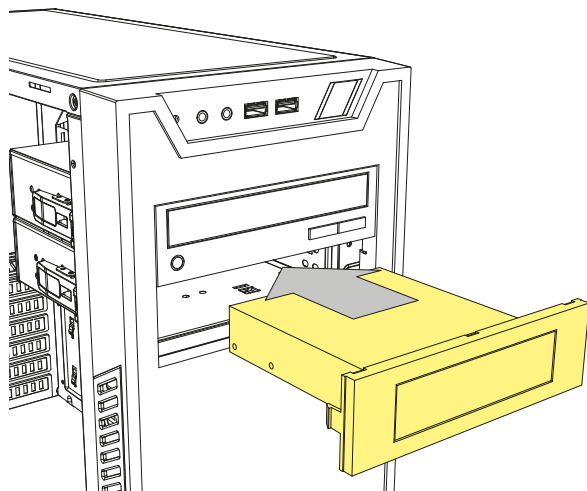
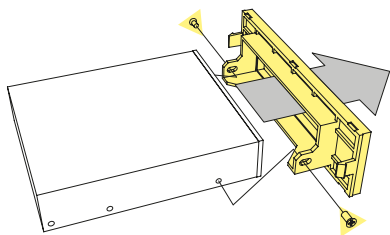

# 3.5" HDD Installation

- Einbau 3,5"-HDD
- Installation disque dur 3,5"
- Installazione HDD da 3,5"
- Instalación de 3,5" HDD
- 3,5" Instalação HDD
- Installatie 3,5" HDD
- 3,5" montaż dysków
- 3,5" HDD beszerelhetőség
- Instalace 3,5" HDD
- Inštalácia 3,5" HDD
- 3,5" 硬碟安裝
- 3.5 インチハードディスクの取付け

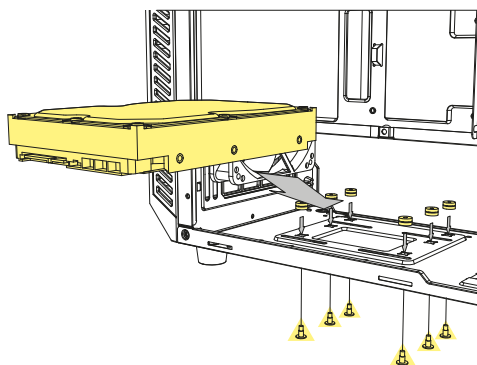
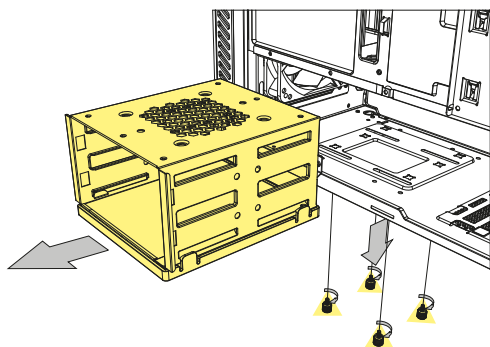
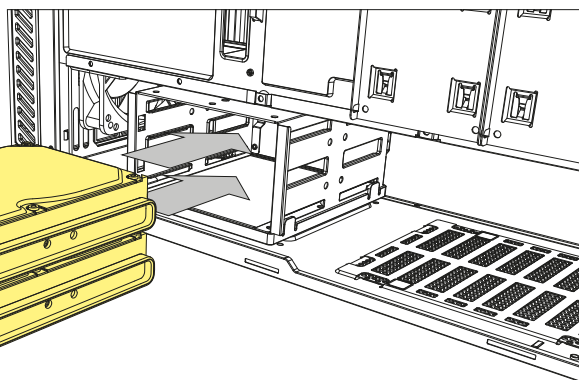
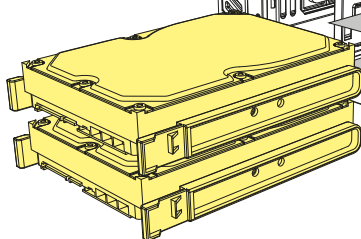
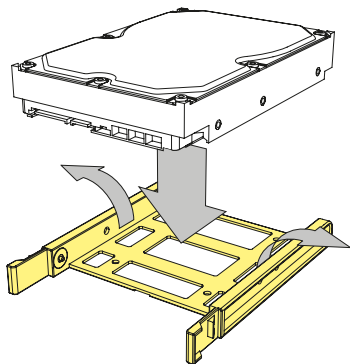

# 2.5" HDD/SSD Installation

- Einbau 2,5"-HDD/SSD
- Installation disque dur/SSD
- Installazione HDD/SSD da 2,5"
- Instalación de 2,5" HDD/SSD
- 2,5" Instalação HDD/SSD
- Installatie 2,5" HDD/SSD
- 2,5" montáž HDD/SSD
- 2,5" HDD/SSD beszerelhetőség
- Instalace 2,5" HDD/SSD
- Instalacia 2,5" HDD/SSD
- 2,5" 硬碟/SSD 安裝
- 2.5 インチ HDD/SSD の取付け

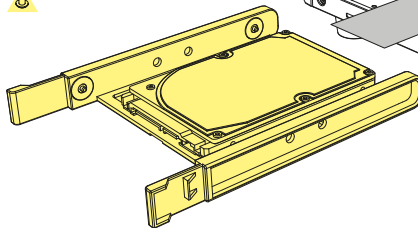
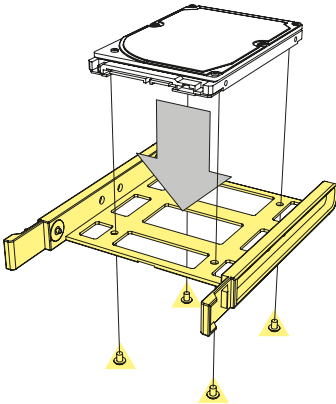
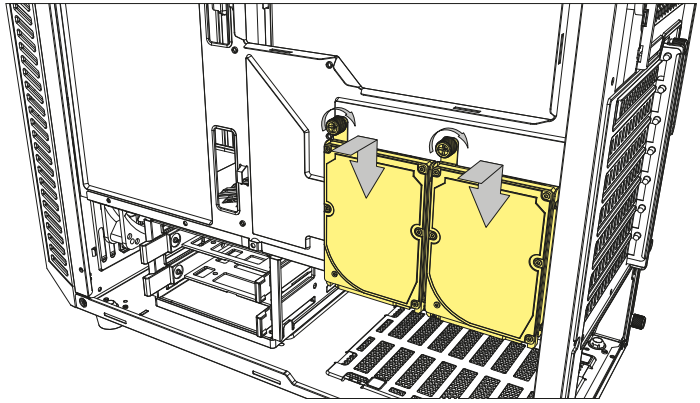
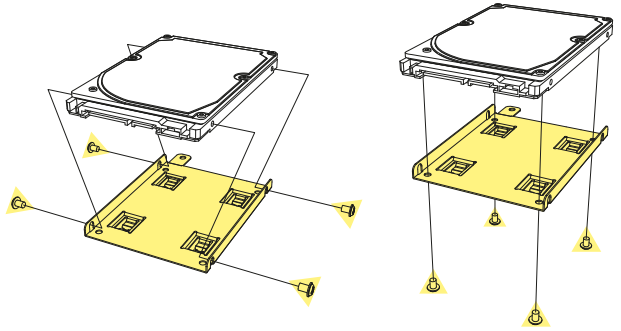
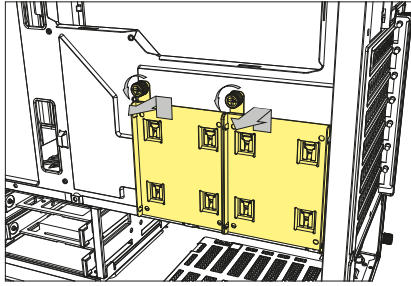

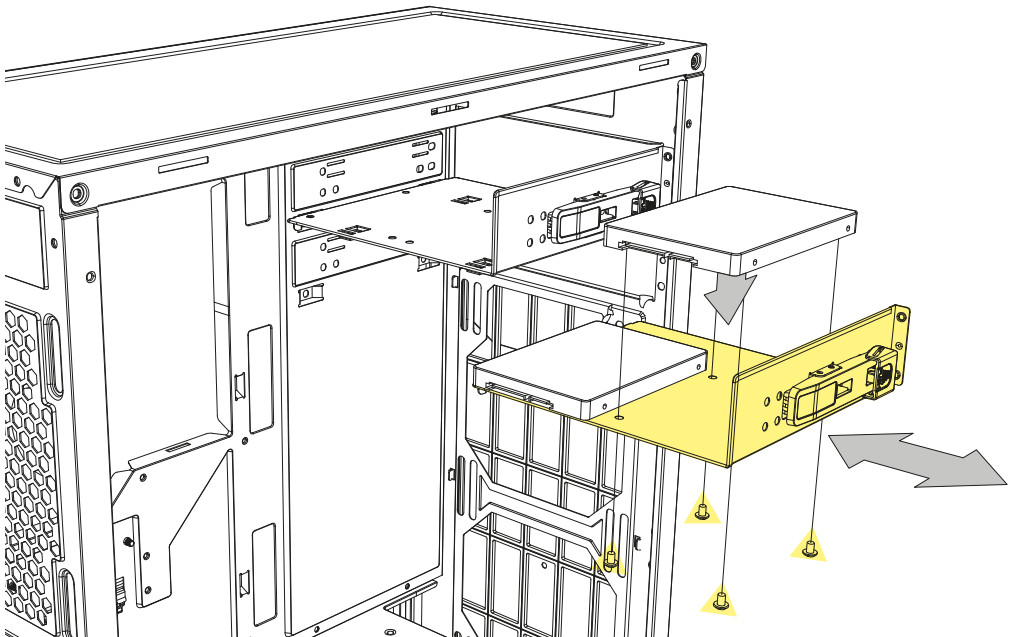
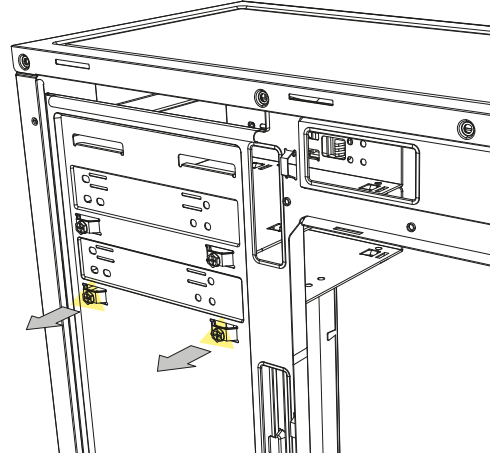
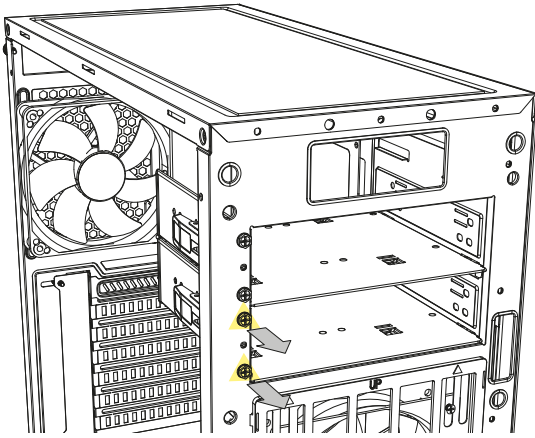

# Add-On Cards Installation

- Einbau Erweiterungskarten
- Installation des cartes d'extension
- Installazione di schede aggiuntive
- Instalación de tarjetas adicionales
- Instalação de cartões adicionais
- Installatie uitbreidingskaarten
- Montaż kart rozszerzeń
- Bővítőkártya beszerelhetőség
- Instalace karet na základní desku
- Inštalácia kariet na základovú dosku
- 介面卡安裝
- 増設カードの取付け

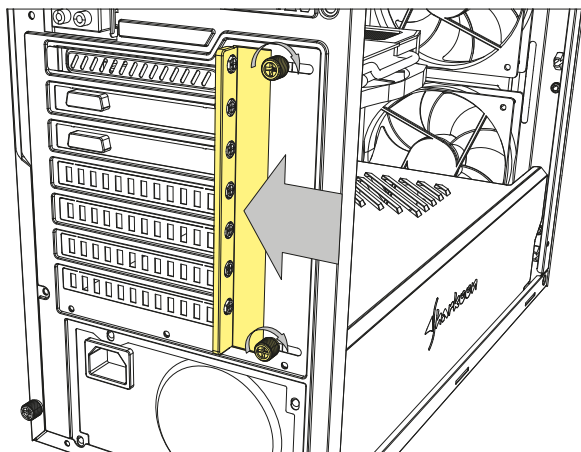
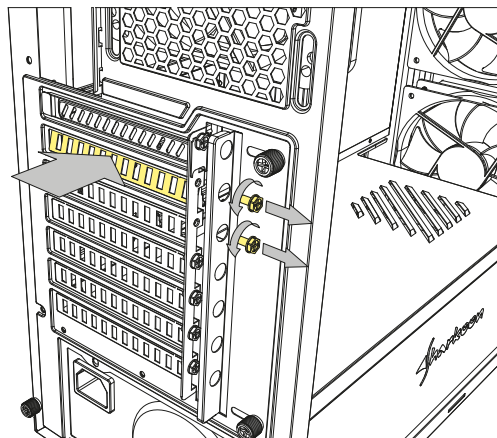
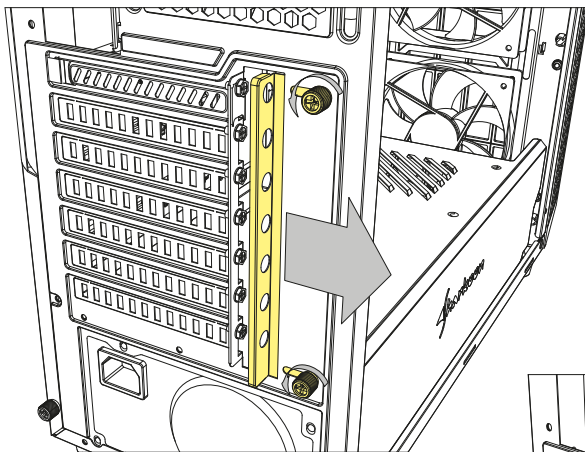

# Detachable Dust Filter

- Herausnehmbarer Staubfilter
- Filtre anti-poussière amovible
- Filtro antipolvere rimovibile
- Filtro de polvo desmontable
- Filtro de poeira destacável
- Afneembaar stoffilter
- Odczepialny filtr przeciwkurzowy
- Levehető porszűrő
- Oddeliteľný prachový filter
- Odnímateľný prachový filter
- 可拆卸式防塵濾網
- 着脱式ダストフィルター

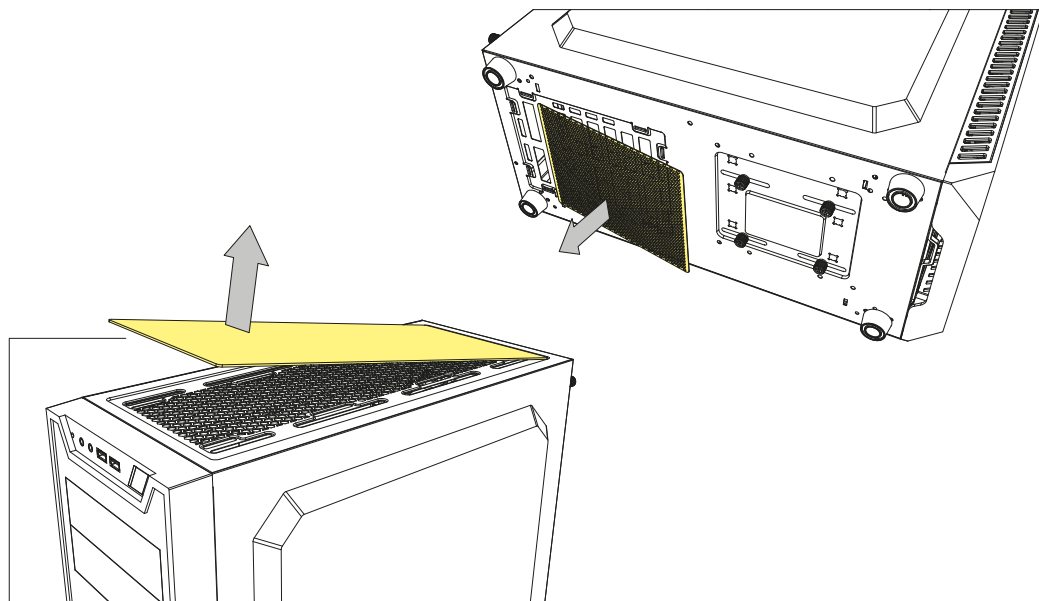

**For window edition only**

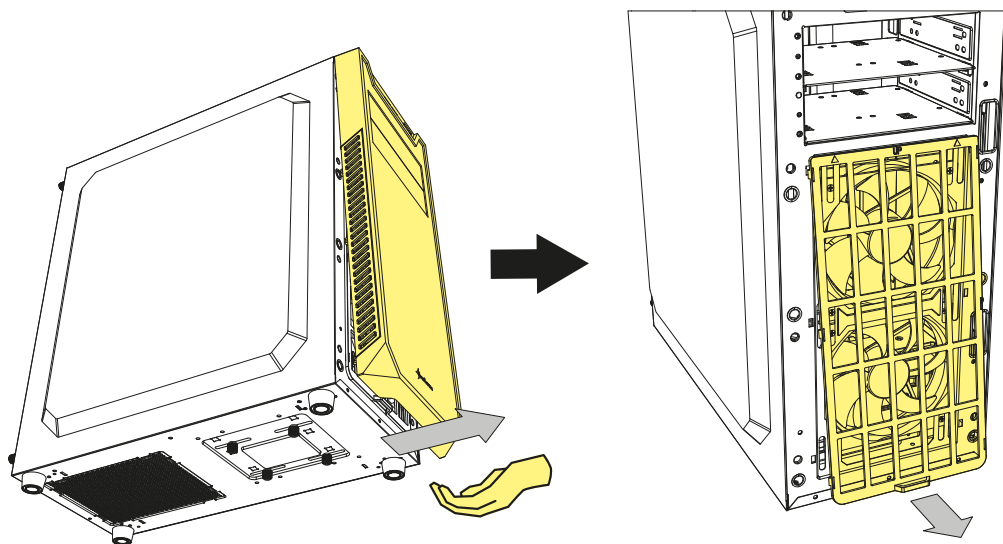



## Extra HDD Cooling Solution

- Optionale HDD-Kühlung
- Solution de refroidissement du disque dur en option
- Soluzione di raffreddamento extra per HDD
- Solución de refrigeración opcional HDD
- Solução de resfriamento opcional HDD
- Optionele HDD-koeling

- Optymalne rozwiązanie do chłodzenia dysku
- Extra HDD-hűtési megoldás
- Instalace extra chlazení HDD
- Inštalácia extra chladenia pre HDD
- 硬碟散熱加強方案
- HDD 冷却強化オプション

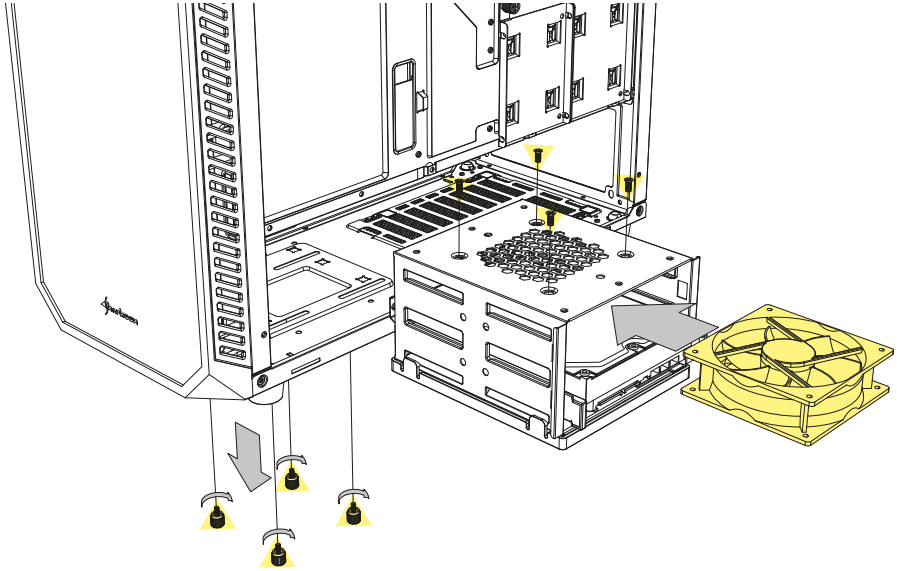

## Extra Space for Power Supply Installation

- Zusätzlicher Platz für die Netzteil-Installation
- Espace supplémentaire pour l'installation de l'alimentation
- Spazio extra per l'installazione dell'alimentatore
- Espacio extra para la instalación de fuente de alimentación
- Espaço extra para a instalação da fonte de alimentação
- Extra ruimte voor installatie van voeding

- Dodatkowe miejsce na montaż zasilacza
- Extra hely a tápegység számára
- Extra prostor pro instalaci napájecího zdroje
- Extra priestor pre inštaláciu napájacieho zdroje
- 增加電源安裝空間
- 電源ユニット設置用の追加スペース

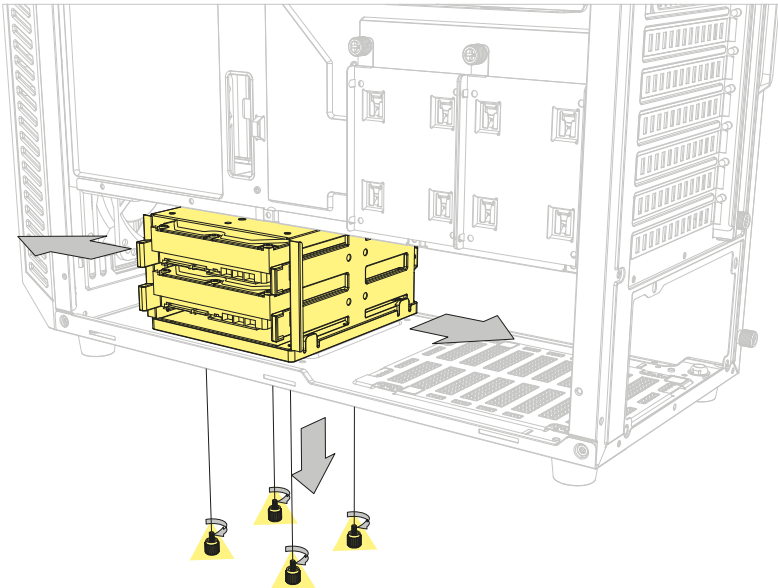

## Top Panel Radiator Installation

- Radiatoreinbau Gehäuseoberseite
- Installation du radiateur supérieur
- Installazione del radiatore pannello superiore
- Instalación de radiador en el panel superior
- Instalação do radiador do painel superior
- Bovenpaneel radiator installatie

- Montáž chladičky na górnym panelu
- A radiátor felszerelése a felső panelre
- Instalace chladiče na horní panel
- Montáž chladiča na horní panel
- 機殻上板水冷排安裝
- トップパネルラジエーターの設置

For window edition only

- 120 mm
- 140 mm
- 240 mm Radiator
- 280 mm
- 360 mm

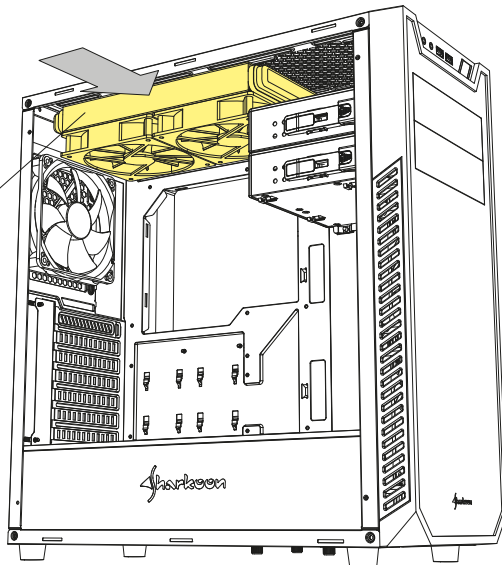

## Front Panel Radiator Installation

- Radiatoreinbau Gehäusefront
- Installation du radiateur frontal
- Installazione del radiatore sul pannello frontale
- Instalación de radiador en el panel frontal
- Instalação do radiador do painel frontal
- Voorpaneel radiator installatie

- Montáž chladičky na panelu prednim
- A radiátor felszerelése az elülső panelre
- Instalace chladiče na přední panel
- Montáž chladiča na predný panel
- 機殻前板水冷排安裝
- フロントパネルラジエーターの設置

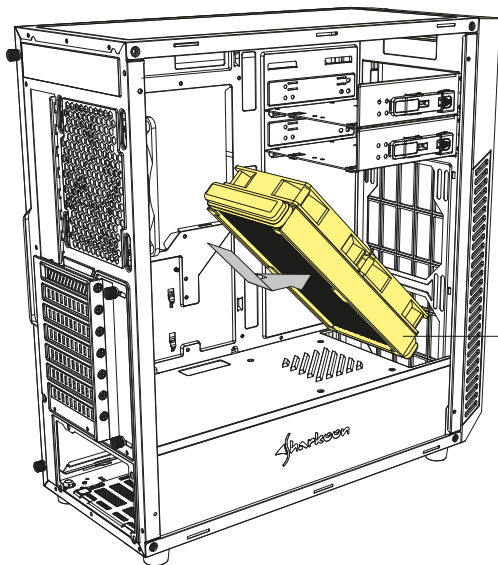

- 120 mm
- 140 mm
- 240 mm Radiator
- 280 mm

# Extra Space for Radiator Installation

- Zusätzlicher Platz für die Radiator-Installation
- Espace supplémentaire pour l'installation de radiateur
- Spazio extra per l'installazione radiatore
- Espacio extra para la instalación de radiador
- Espaço extra para a instalação da radiador
- Extra ruimte voor installatie van radiator

- Dodatkové miesta na montáž chladičov
- Extra hely a radiátor számára
- Extra prostor pro instalaci chladiče
- Extra priestor pre inštaláciu radiátor
- 增加水冷排安裝空間
- ラジエーター設置用の追加スペース

**For window edition only**

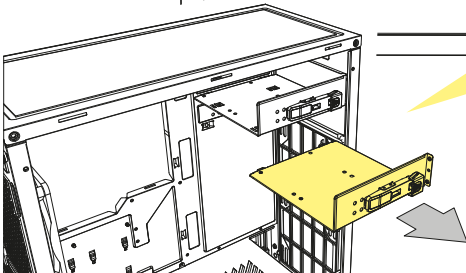
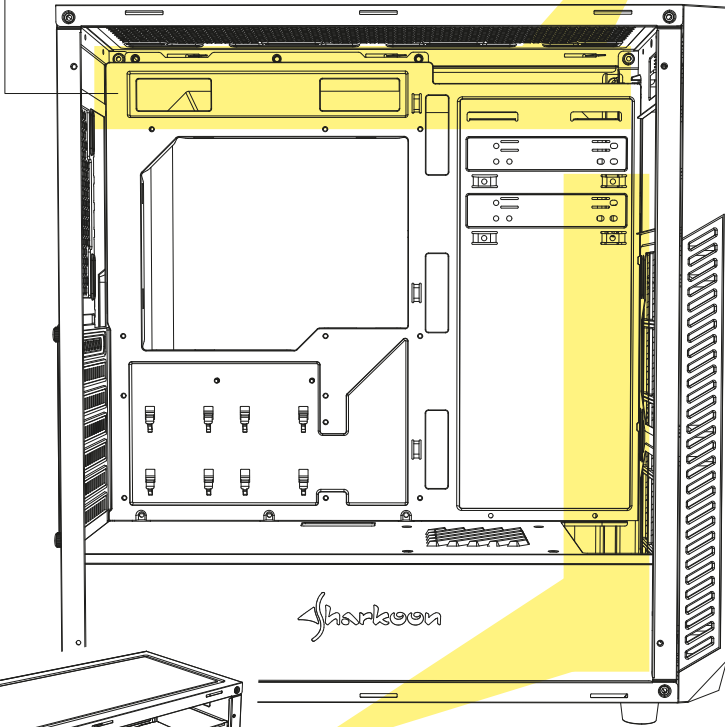
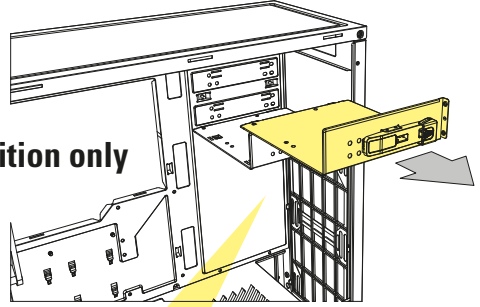

# Rear Panel Radiator Installation

- Radiatoreinbau Gehäuserückseite
- Installation du radiateur arrière
- Installazione del radiatore pannello posteriore
- Instalación de radiador en el panel posterior
- Instalação do radiador no painel traseiro
- Achterpaneel radiator installatie
- Montaz chlodyny na panelu tylnym
- A radiátor felszerelése a hátsó panelre
- Instalace chladiče na zadní panel
- Montáž chladiča na zadný panel
- 機殻後板水冷排安裝
- リアパネルラジエーターの設置

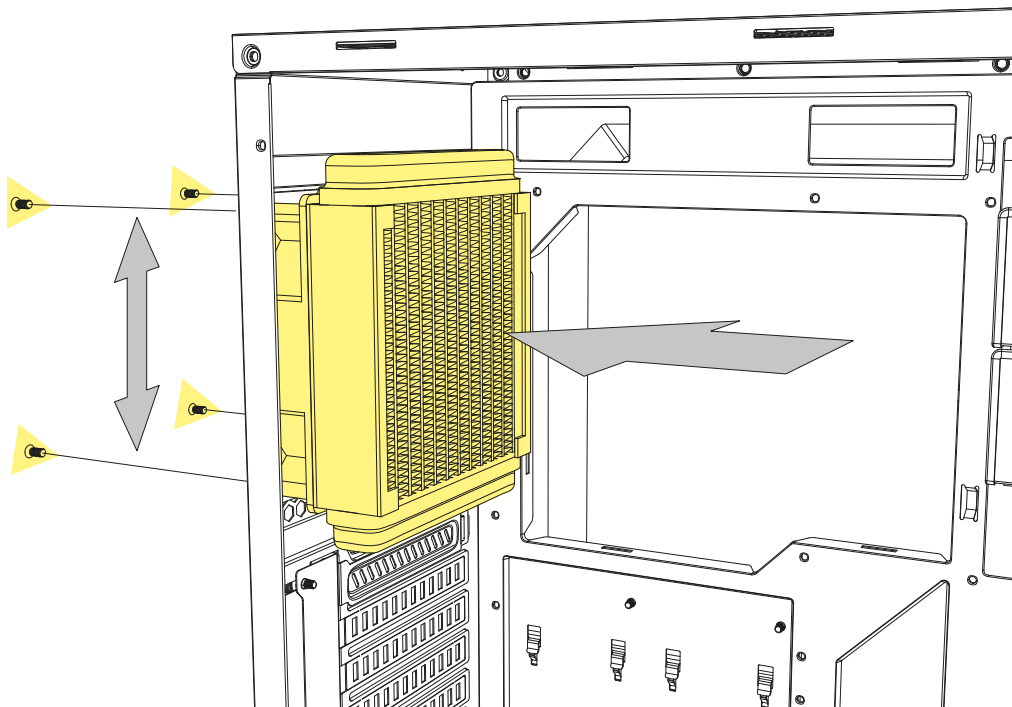

**120 mm Radiator**

## Legal Disclaimer

For potential loss of data, especially due to inappropriate handling, SHARKOON assumes no liability. All named products and descriptions are trademarks and/or registered trademarks of the respective manufacturers and are accepted as protected. As a continuing policy of product improvement at SHARKOON, the design and specifications are subject to change without prior notice. National product specifications may vary. All rights reserved especially (also in extracts) for translation, reprinting, reproduction by copying or other technical means. Infringements will lead to compensation. All rights reserved especially in case of assignation of patent or utility patent. Means of delivery and technical modifications reserved.

## Disposal of your old products

Your product is designed and manufactured with high quality materials and components, which can be recycled and reused.



When this crossed-out wheeled bin symbol is attached to a product, it means the product is covered by the European Directive 2012/19/EU. Please be informed about the local separate collection system for electrical and electronic products. Please act according to your local rules and do not dispose of your old products with your normal household waste. The correct disposal of your old product will help prevent potential negative consequences to the environment and human health.

## Rechtliche Hinweise

Für evtl. auftretenden Datenverlust, insbesondere durch unsachgemäße Handhabung, übernimmt SHARKOON keine Haftung. Alle genannten Produkte und Bezeichnungen sind Warenzeichen und/oder eingetragene Warenzeichen der jeweiligen Hersteller und werden als geschützt anerkannt. Als ein Teil von SHARKOONs Politik der fortwährenden Produktverbesserung unterliegen Produktdesign und -spezifikationen Änderungen ohne vorherige Ankündigung. Die Spezifikationen können in verschiedenen Ländern variieren. Alle Rechte vorbehalten, insbesondere (auch auszugsweise) die der Übersetzung, des Nachdrucks, der Wiedergabe durch Kopieren oder ähnliche Verfahren. Zuwiderhandlungen verpflichten zu Schadenersatz. Alle Rechte vorbehalten, insbesondere für den Fall der Patenterteilung oder GM-Eintragung. Liefermöglichkeiten und technische Änderungen vorbehalten.

## Entsorgung Ihres alten Gerätes

Ihr Gerät wurde unter Verwendung hochwertiger Materialien und Komponenten entwickelt und hergestellt, die recycelt und wiederverwendet werden können.



Befindet sich dieses Symbol (durchgestrichene Abfalltonne auf Rädern) auf dem Gerät, bedeutet dies, dass für dieses Gerät die Europäische Richtlinie 2012/19/EU gilt. Informieren Sie sich über die geltenden Bestimmungen zur getrennten Sammlung von Elektro- und Elektronik-Altgeräten in Ihrem Land. Richten Sie sich bitte nach den geltenden Bestimmungen in Ihrem Land, und entsorgen Sie Altgeräte nicht über Ihren Haushaltsabfall. Durch die korrekte Entsorgung Ihrer Altgeräte werden Umwelt und Menschen vor möglichen negativen Folgen geschützt.

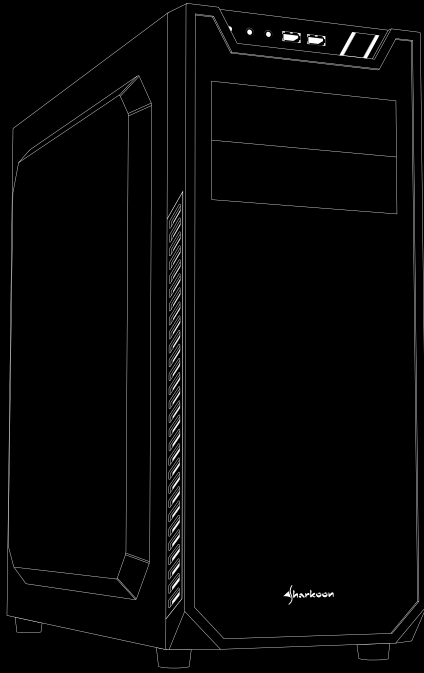

**SHARKOON Technologies GmbH**  
Siemensstraße 38  
35440 Linden  
Germany

© **SHARKOON Technologies 2018**

info@sharkoon.com  
www.sharkoon.com